



2190 Boul. Dagenais West  
LAVAL (QUEBEC)  
CANADA  
H7L 5X9

TEL: 514.337.4415  
FAX: 514.337.4029  
info@burcam.com

# INSTALLATION INSTRUCTIONS

## MODELS

506120S

506220S

503120S

503220S

506530SSW

506530SSN

## SPRINKLER PUMPS

Your pump has been carefully packaged at the factory to prevent damage during shipping. However, occasional damage may occur due to rough handling. **Carefully inspect your pump** for damages that could cause failures. Report any damage to your carrier or your point of purchase.

**Factory set voltage 115 V  
Connection voltage changing:**

Before changing the voltage connection:

- A) Ensure the power to the pump is disconnected.
- B) Open motor junction box cover.
- C) Please select the up knob position for 115 V or down knob position for 230 V.

or

Pull voltage selector knob 1/4" and align arrow with desired connection voltage.

- D) Push back in voltage selector knob.
- E) Close motor junction box.



Please read these instructions carefully. Failure to comply to instructions and designed operation of this system, may void the warranty.

ILLUSTRATED MODEL  
**506120S**

# SAFETY INSTRUCTIONS:

This fine pump that you have just purchased is designed from the latest in material and workmanship.

Before installation and operation, we recommend the following procedures:

- A** CHECK WITH YOUR LOCAL ELECTRICAL AND PLUMBING CODES TO ENSURE YOU COMPLY WITH THE REGULATIONS. THESE CODES HAVE BEEN DESIGNED WITH YOUR SAFETY IN MIND. BE SURE YOU COMPLY WITH THEM.
- B** WE RECOMMEND THAT A SEPARATE CIRCUIT BE LEAD FROM THE HOME ELECTRICAL DISTRIBUTION PANEL PROPERLY PROTECTED WITH A FUSE OR A CIRCUIT BREAKER. WE ALSO RECOMMEND THAT A GROUND FAULT CIRCUIT BE USED. CONSULT A LICENSED ELECTRICIAN FOR ALL WIRING.
- C** THE GROUND TERMINAL ON THE THREE PRONG PLUGS SHOULD NEVER BE REMOVED. THEY ARE SUPPLIED AND DESIGNED FOR YOUR PROTECTION.
- D** NEVER MAKE ADJUSTMENTS TO ANY ELECTRICAL APPLIANCE OR PRODUCT WITH THE POWER CONNECTED. DO NOT ONLY UNSCREW THE FUSE OR TRIP THE BREAKER, REMOVE THE POWER PLUG FROM THE RECEPTACLE.

## Material required for drilled well application (indoor use only)

### Shallow well pump installation

- Desired length of polyethylene 1" pipe, 100 PSI, CSA or UL approved, to link up from pumping level to pump.
- 1 1" foot valve (750756 or 750752P).
- 1 well seal, as per well casing diameter (750929 6" x 1").
- 1 1" well seal elbow (750860).
- 2 1" male adaptors (750865 or 750871).
- 8 1" stainless steel clamps (750885).
- Teflon tape.

### Tools

Screwdrivers, hacksaw to cut pipe, knife to assist in pipe cutting, round file to smooth pipe ends, pipe wrench, adjustable wrench to tighten fittings, propane torch and welding material.

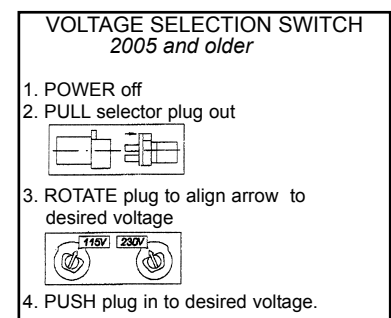
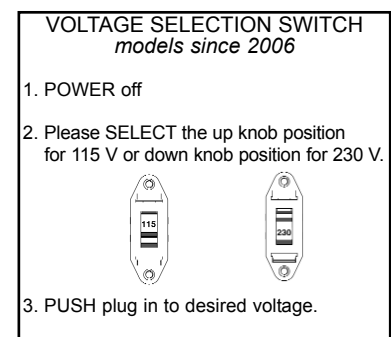

## APPLICATION

- This pump is designed for shallow well installation for water level up to 25 feet.
- Capacity:

Suction	506120S	506220S	503120S	503220S	506530SSN	
5'	715	800	710	754	897	US GPH
10'	630	690	622	659	749	US GPH
15'	575	625	548	581	638	US GPH
20'	500	545	474	502	555	US GPH
25'	450	480	437	463	472	US GPH

FRICITION LOSS IN  
PIPE NOT INCLUDED

## FEATURES

- Specially treated cast iron pump body or stainless steel. Easy to prime
- Totally enclosed, fan cooled motor, bearing to bearing. Built for a continuous use.
- Full time connected run capacitor, to eliminate starting wear vs regular motor.
- Thermal and overload protection.
- Noryl impeller, built-in injector
- 1/2HP, 115VAC, 60Hz, 8A, (16A when start).  
3/4HP, 115VAC, 60Hz, 9A, (18A when start).

# INSTALLATION STEPS

**STEP 1** We recommend that you install your pump in a clean and dry location where there is adequate room for servicing at a later date. Protection from freezing temperatures and good ventilation should be considered as well, to provide the pump an environment for long life. Locating the pump as close as possible to the water source will reduce friction losses encountered in the suction pipe.

Friction losses in the suction pipe must be taken into consideration when the horizontal offset is greater than 50 feet. The suction pipes should be increased from 1" to 1 1/4". This will reduce friction losses and allow the pump to give maximum performance.

A new well should be checked to determine that it is free from sand. Sand will damage the seal and the impeller. Have your well driller clean the well before your installation.

**Never run the pump dry.** Damage to the seal may occur. Fill pump body and suction pipe with water before turning on the power.

**THE RUN OF HORIZONTAL PIPE FROM THE TOP OF YOUR WELL INTO THE HOUSE, WHERE YOUR PUMP WILL BE LOCATED, MUST BE INSTALLED IN A TRENCH, BELOW THE FROST LEVEL OF YOUR AREA.**

# SHALLOW WELL APPLICATION

SEE DIAGRAM ON PAGE 5

**STEP 2** Cut the desired length of poly pipe to run from the top of the well to the pumping level. Smooth the pipe cuttings with your round file. (Check that no cut-out parts are left inside of pipe. This may block pump injector or impeller).

Tape male adaptor threads with teflon tape and thread adaptor into the foot valve.

Slide 2 stainless steel clamps over one end of pipe and use torch to soften pipe. Insert the male adaptor and foot valve into this pipe end. Tighten clamps with screwdriver when cool.

**For security against leaks, we suggest to install 2 stainless steel clamps on each adaptor.**

**STEP 3** Insert the well seal elbow thru the opening of the seal.  
Slide 2 stainless steel clamps over the free end of the previously cut pipe and soften pipe with your torch. Attach pipe to the well seal elbow (end protruding at bottom of well seal). Tighten clamps with screwdriver when cool.

**STEP 4** Install the well seal and piping assembly into your well casing. Tight down the well seal bolts using your adjustable wrench.

To facilitate servicing at a later date, you may use a pitless adaptor and a sealed well cap instead of an elbow and a well seal as describe in steps 3 and 4.

**STEP 5** Install your pump in the house, on a sound foundation, as close as possible to the water source. Locate and screw your injector body to your pump body. Locate the suction inlet in the front of the injector. Thread an adaptor into inlet using teflon tape. Do not over tighten.

**STEP 6** Cut the desired length of pipe from pump location to the well seal and connect both ends using the previous way, with stainless steel clamps and torch.

**Do not fill in your trench to the house until you have checked for any leaks in your connections or trouble in your water system.**

**STEP 7** Sand or well points are limited to areas where water bearing sand or gravel lies below the surface, and where there are no boulders or rocks to interfere with the driving into the ground of the point.

**for sand or well points** The amount of water any "one" well point will supply is usually rather limited. Sometimes, it is necessary to use more than one point to increase the supply of water, entering to the pump's suction.

THE IMPORTANT INSTALLATION STEP IN USING WELL POINTS IS THAT A CHECK VALVE MUST BE USED IN THE SUCTION PIPE LEADING TO THE SUCTION INLET, AS CLOSE TO THE PUMP AS POSSIBLE, TO KEEP SUCTION LINE AND PUMP WELL PRIMED.

**STEP 8** Do not use an extension cord to connect your pump to the power source. From your distribution panel to the pressure switch, we recommend a wire gauge not smaller than 14 gauge.

# SHALLOW WELL APPLICATION

**STEP 5** Install your pump and thread an adaptor into inlet.

**STEP 6** Cut poly pipe and connect both ends.

**STEP 3** Insert well seal elbow thru the seal and attach to pipe.

**STEP 4** Install well seal and piping into well casing.

**STEP 2** Cut poly pipe and install the check valve.

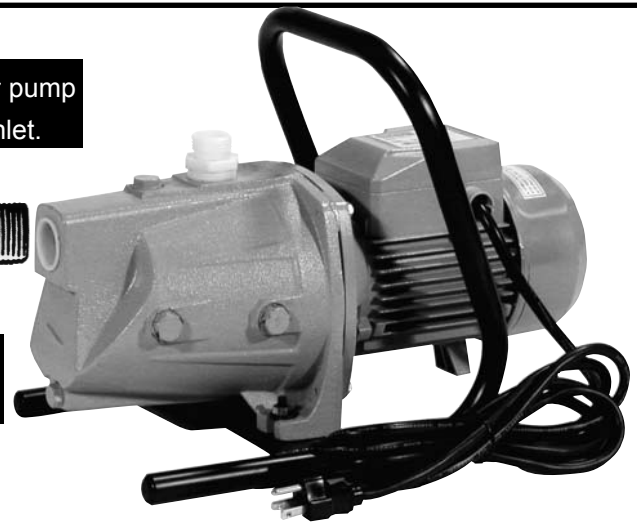

## Well point optional installation

**STEP 7** You may install one or more sand points to increase the supply of water.

Check valve, close to pump.

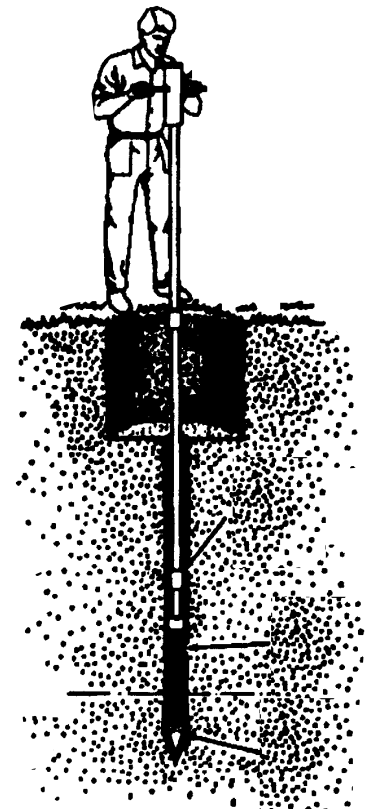
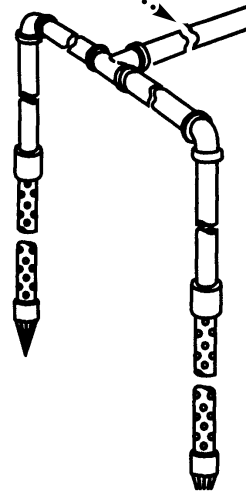

# REPAIR PARTS

REF	PARTS	DESCRIPTIONS	REF	PARTS	DESCRIPTIONS
1	506391	Cast iron pump body	22	506073GP	Motor fan
2	750769	Pressure gauge	23	506072GP	Motor end bell
3	52319	1/4"NPT 1/8"barb brass adaptor	24	506385	Wave spring washer
4	506389	Nozzle	25	350335	Motor bearing fan side
5	750748	Plastic tubing	26	506070GP	Rotor/shaft
6	506052	Nozzle O-ring	27	506069	Rotor shaft key
7	506380	Venturi	28	350335	Motor bearing pump side
8	506388	Venturi O-rings (2)	29	750957S	Pressure switch
9	506387	Diffuser	30	506075	Motor/pump foot
10	506055	Impeller brass nut	31	506300	Priming plugs (2)
11	506381	Gasket	32	506400	Priming plug washers (2)
12	506056P	Noryl impeller	33	506067GP2V	Stator winding
13	506382	Snap Ring	34	506386	Grounding screw
14	506057	Mechanical shaft seal	35	506065	Capacitor junction block
15	350129	Pump body O-ring	36	506094	115/230V selector
16	506059GP	Stainless steel seal plate	37	506064	Motor capacitor
17	506060	Sand slinger	38	506014	Cover box junction
18	506062	Body cap screw	39	506384	Cover box screw
19	506061GP	Pump bracket	40	506601	Handle for spinkler model
20	506383	Motor flange cap screw	41	52257	Reducer 1" to garden hose.
21	506074GP	Fan cover			

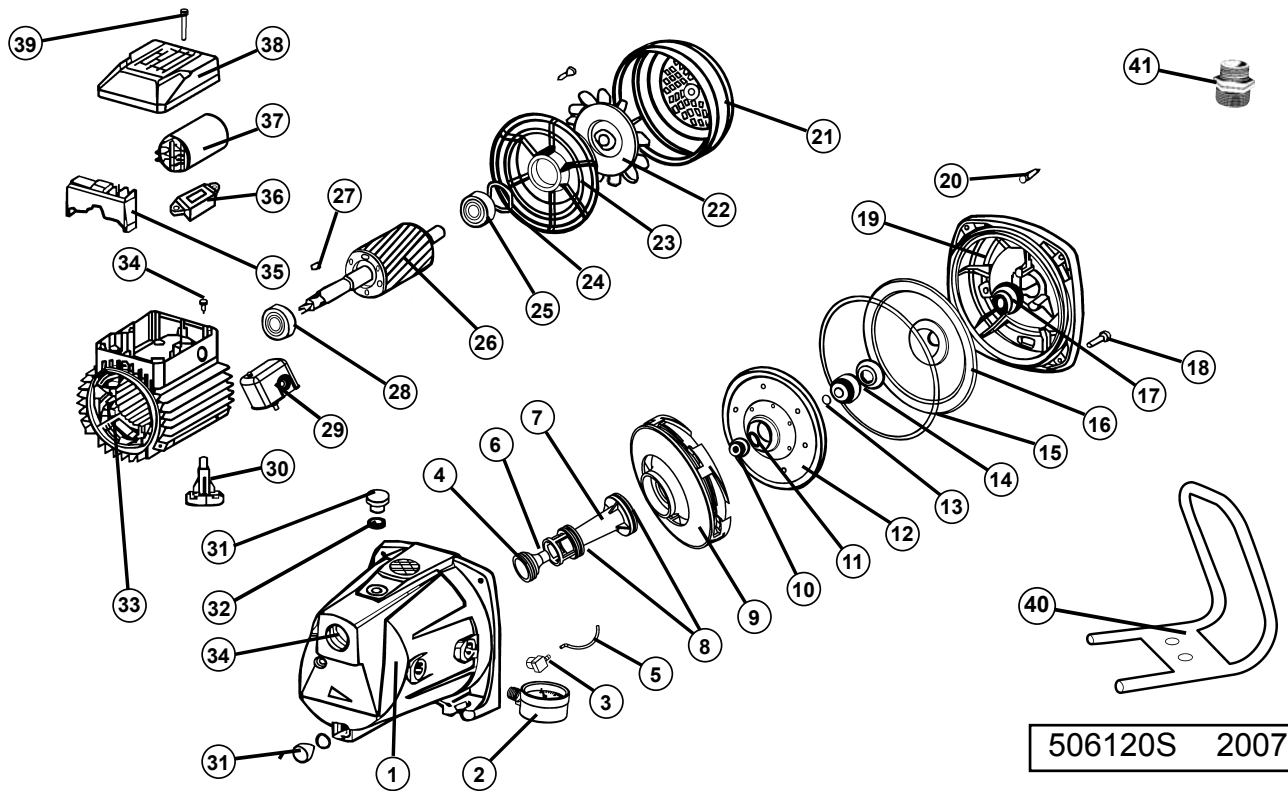

Repair parts may be ordered from your authorized point of sale or from  
**BUR-CAM PUMPS**

# REPAIR PARTS

REF.	PART	DESCRIPTION	REF.	PART	DESCRIPTION
1	506400	Washer	21	506014	Junction box cover
2	506300	Drain and/or priming plug	22	506065OS	Junction box
3	506402	Pump body	22	506065	Junction box
4	506051	Nozzle	23	506030GP	Stator
5	506052	Nozzle O-ring	24	506015	Capacitor
6	506053	Venturi O-ring	25	506031	Pump side bearing
7	506406	Venturi	26	506318	Shaft key impeller
8	506053	O-ring	27	506314GP	Rotor
9	506317	Diffuser	28	506032	Fan side bearing
10	506022	Impeller nut	29	506428	Wavy washer
11	506292P	Impeller	30	506296	Motor end bracket
12	506411	Snap ring	31	506430	Screws (3)
13	506288	Pump body O-ring	32	506017	Fan
14	506309	Mechanical seal	33	506016	Fan cover
15	506287	Seal plate	34	506094	115/230V selector (since 2006)
16	506415	Screws (3)	34	506093	115/230V selector (2004-2005)
17	506416	Sand slinger	34	506093IOS	115/230V selector (before 2004)
18	506289	Pump bracket	35	506312	Motor/pump foot
19	506297	Body cap bolts (4)	36	506601	Handle for spinkler model
20	506419	Box cover screw	37	52257	Reducer 1" NPT to garden hose
21	506014OS	Junction box cover	38	52212	Brass plug

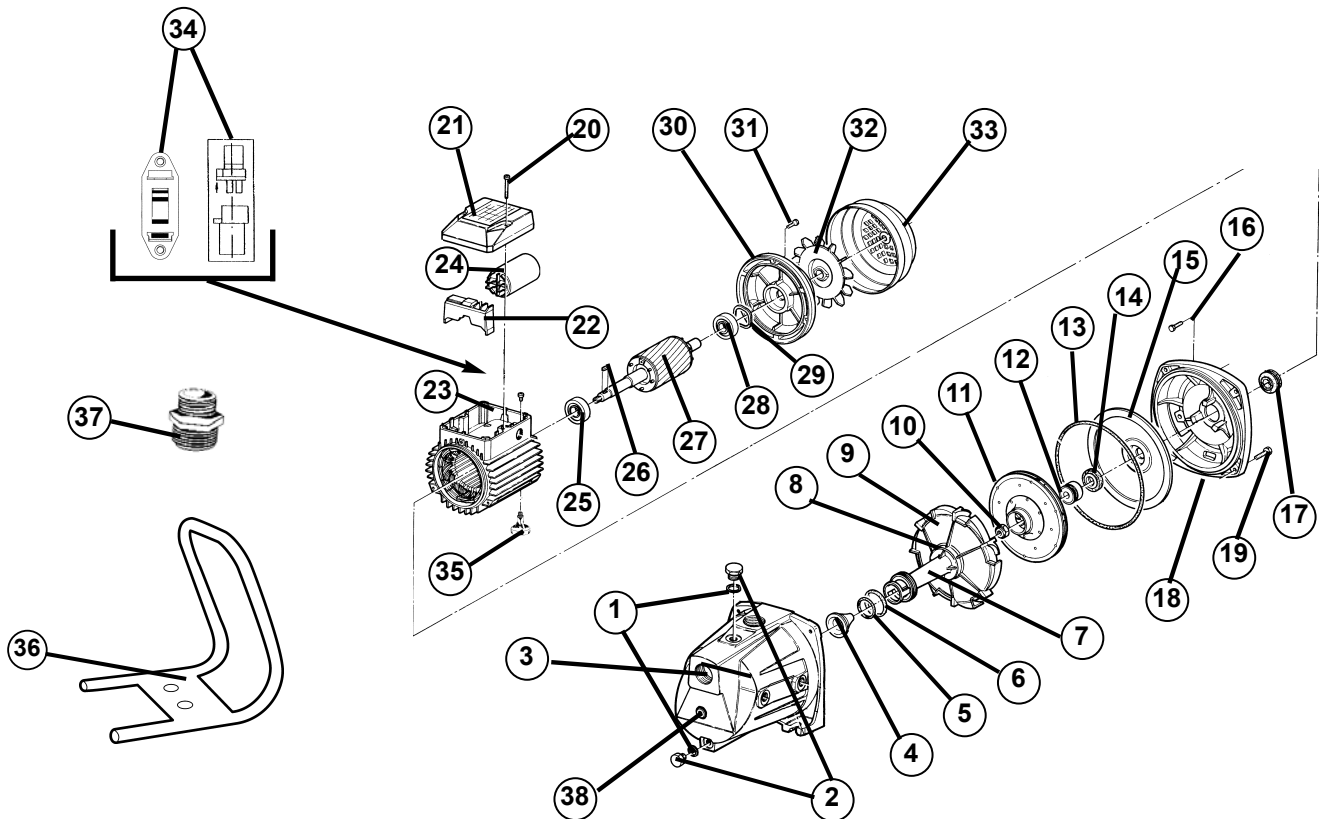

506220S 2002

Repair parts may be ordered from your authorized point of sale or from  
**BUR-CAM PUMPS**

# REPAIR PARTS

REF.	PARTS	DESCRIPTION	REF.	PARTS	DESCRIPTION
1	510054	Motor 1/2HP	11	510051	Diffuseur plate O-ring
1	510054-2	Motor 3/4HP	12	510050	Diffuseur plate washers (3)
2	510055	Motor screws (4)	13	510049	Diffuseur plate screws (3)
3	750957S	Pressure switch	14	510069	Venturi
4	510056	1/4"NPT 1/4" Barb elbow	15	510046	Nozzle
5	750748	Hose	16	510056	1/4" NPT 1/4" Barb elbow
6	510053	Seal plate O-ring	17	510045	Cast iron pump body
7	510052	Mechanical seal	18	750769	Pressure gauge (not shown)
8	510048	Impeller	19	506601	Handle for springkier model
9	510047	Diffuseur	20	52257	Reducer 1" NPT to garden hose
10	510065	Diffuseur plate			

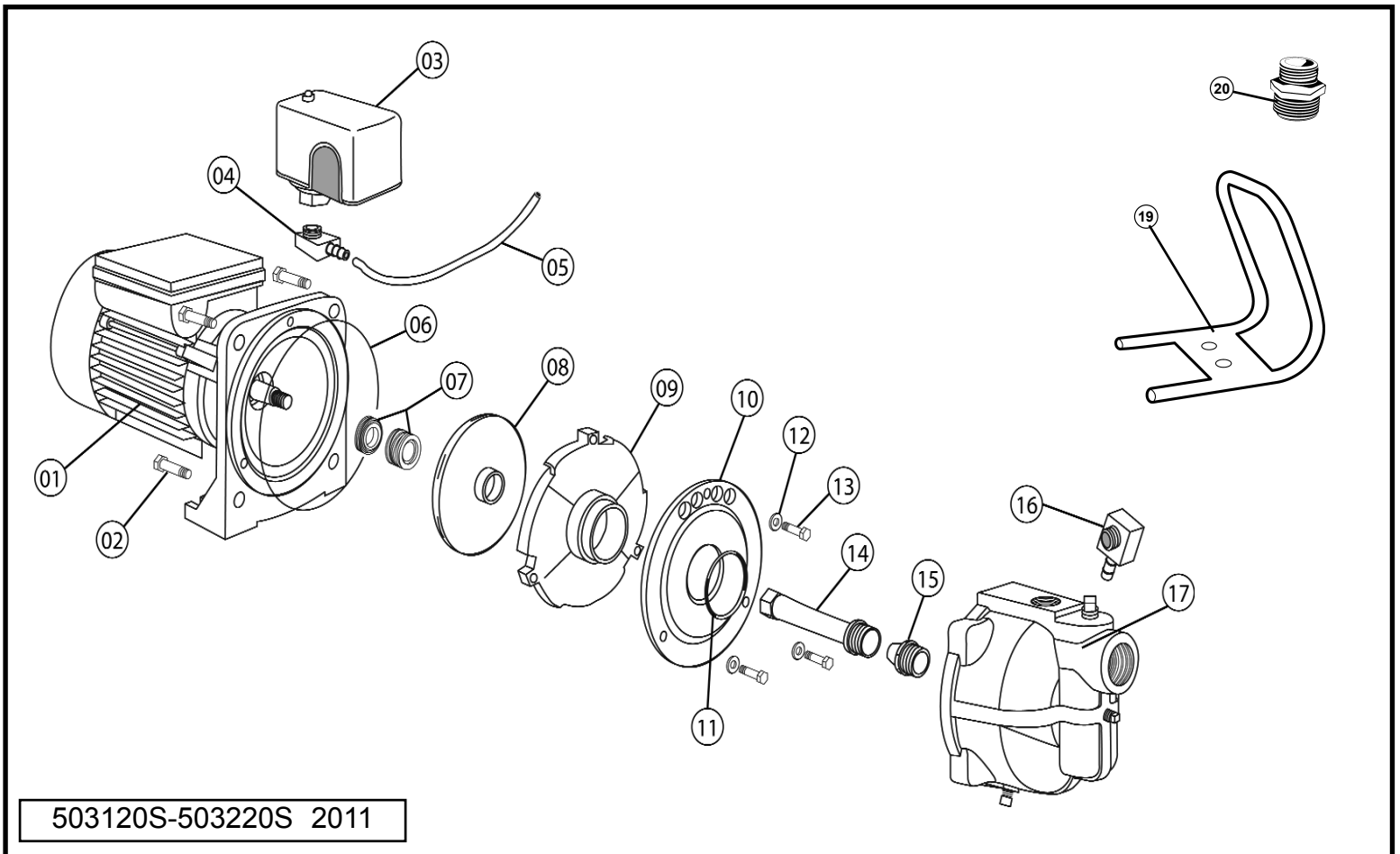

Repair parts may be ordered from your authorized point of sale or from  
**BUR-CAM PUMPS**



# REPAIR PARTS

REF.	PARTS	DESCRIPTION
1	506101	Stainless steel pump body
2	506052S	Nozzle O-ring
3	506042S	Venturi
4	506053S	Venturi O-ring
5	506085	Diffuser
6	506055	Impeller nut
7	506083	Impeller
8	506057	Mechanical seal
9	506084	Pump body O-ring
10	506095	Seal plate
11	506060	Sand slinger
12	506103	Pump bracket
13	506105	Pump body screws (8)
14	506014OS	Junction box cover
14	506014	Junction box cover
15	506064	Capacitor
16	506065OS	Capacitor junction box
16	506065	Capacitor junction box
17	506097	Stator
18	350335	Bearing pump side
19	506098	Shaft key
20	506099	Rotor shaft
21	350335	Bearing fan side
22	506100	Motor end bell
23	506073GP	Motor Fan
24	506074GP	Fan cover
25	506104	Motor / pump foot
26	506076	Drain / priming plug
27	506094	115/230V selector
28	506419	Cover screws
33	506601	Handle for sprinkler model (Not shown)
34	52257	Reducer 1" NPT to garden hose

REF.	PARTS	DESCRIPTION
1	510000	Pump body
2	510001	Priming / drainage plug
3	750769	Pressure gauge
4	510003	Pump body screw (6)
5	510004	Venturi O-ring
6	510005	Venturi / diffuser
7	510006	Impeller
8	510007	Washer
9	510008	Mechanical seal
10	510009	Seal plate O-ring
11	510010	Seal plate
12	510011	Water slinger
13	510012	Motor
14	510013	Capacitor
15	510014	Junction box cover
51	510022	Base plate
52	510023	Base plate bolts (2)
53	510024	Base plate washers (4)
54	510025	Base plate nuts (2)
55	510026	Nut
56	510027	Handle
57	510028	Washer
58	510029	Bolt
59	510030	Handle cover
60	510031	Power cable
61	510037	Capacitor holder

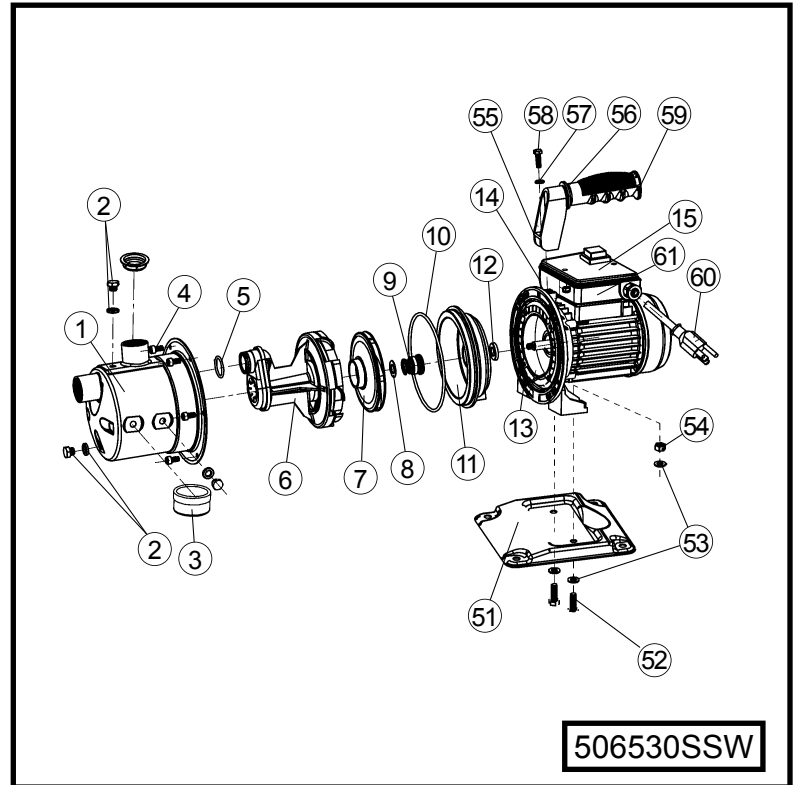
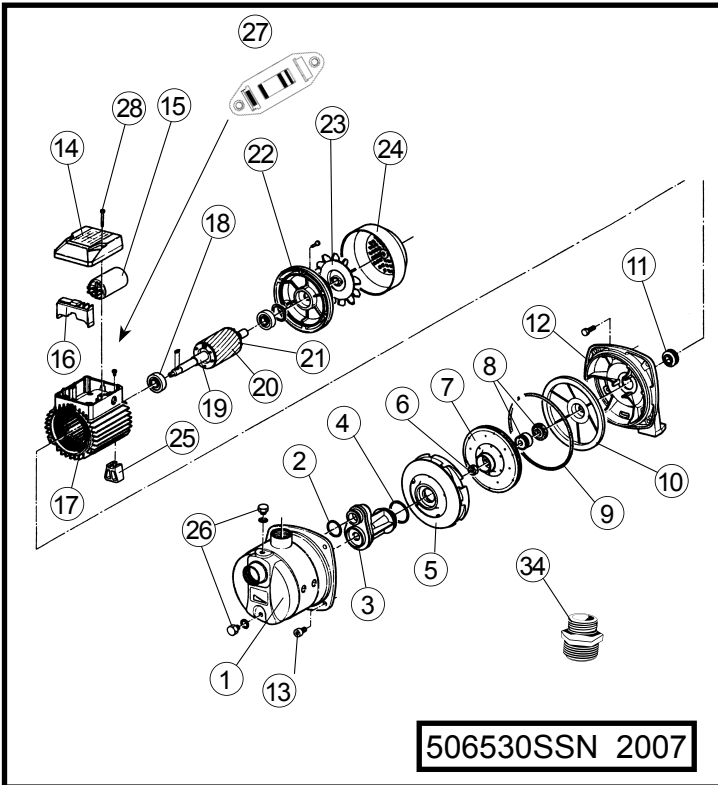

Repair parts may be ordered from your authorized point of sale or from  
BUR-CAM PUMPS

# TROUBLE SHOOTING GUIDE CHECKLIST

NEVER MAKE ADJUSTMENTS TO ANY ELECTRICAL APPLIANCE OR PRODUCT WITH THE POWER CONNECTED. DON'T JUST UNSCREW THE FUSE OR TRIP THE BREAKER, REMOVE THE POWER FROM THE RECEPTACLE.

TROUBLE	PROBABLE CAUSE	ACTION
Motor does not run.	Switch is off position Blown fuse Tripped breaker Dirty pressure switch Defective pressure switch Defective motor	Turn switch to on position Replace Reset Clean Replace Replace
Motor runs but no water is delivered.	Pump not primed Leaky suction line Foot valve plugged Ejector nozzle clogged Water level below foot valve Suction lift to great Improper voltage	Prime with clean water Check pipe and pipe connections Clean Clean Check foot valve level Water level lower than lift capacity Check voltage
Pump does not deliver to full capacity.	Water level below foot valve Ejector nozzle clogged Excessive friction in pipe Improper voltage	Check foot valve level Clean Too small or dirty pipe Check voltage
Air spurts from faucets.	Leaky suction line Gaz in water	Check pipe and pipe connections Check and consult factory

## TO THE END CONSUMER

*If you have any problems with the product, before advising the store, where you've purchased the pump, please contact us at 514 337-4415 , and ask for our sales department, and they will be pleased to help you with any questions you might have, concerning your installation.*