

TURBO[®]

Model T30527

SUBMERSIBLE SUMP PUMP

Professional Series

2 YEAR WARRANTY



3/4HP
4000 GPH
Head of
25' (7,5 m)

Discharge:
 1 1/2" NPT with elbow
 Electric cables:
 19' piggyback type

- Water cooled
- Stainless steel construction
- Noryl vortex impeller
- Stainless Steel mechanical rotary seal
- Automatic mechanical switch

115V 60Hz
 5.5A, (10A at start)

	US GPH	LPH
5'	4000	15100
10'	3200	12100
15'	2300	8700
20'	1300	4900
25'	200	750

Friction loss not included

REPAIR PARTS

REF.	PART	DESCRIPTION
1	310585	Nut and bolt for handle
2	310586	Handle
3	310587	Square support screw (2)
4	310588	Handle square support (2)
5	310589	Motor assembly
6	310590	Impeller
7	310591	Impeller lock nut
8	310592	Pump body screws (6)
9	310593	Gasket
10	310594	Pump body
11	450453	Mechanical float

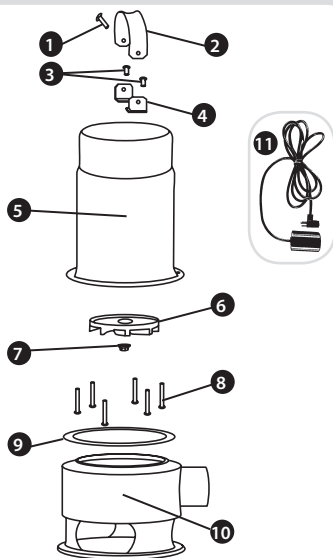

TURBO

TO THE PROFESSIONAL OR INSTALLER:
Instructions must remain with installation.

GENERAL SUMP PUMP INSTALLATION

Please read these instructions carefully. Note before you proceed with the installation of this product that the manufacturer's guideline has to be respected. Failure to comply to instructions and designed operation of this product, may void the warranty.

Your product has been carefully packaged at the factory to prevent damage during shipping. However, occasional damage may occur due to rough handling. Carefully inspect your product for damages that could cause failures. Report any damage to your carrier or your point of purchase.

MONTHLY MANDATORY CHECK-UP:

- 1- Inspect the pump and the sump for any obvious condition that necessitates cleaning, correction, adjustment or repair.
- 2- Clear the sump and the surroundings of any paper, leaves or other debris that might clog the input openings. Remove anything that might float into the sump.
- 3- Assure that the pump is secure and vertical for proper operation.
- 4- Assure that there is adequate clearance from any combustible materials or structure. Stored materials must be kept away from the pump. Shelves or cabinet structures must not be in close proximity over the pump.
- 5- Assure that the motor is securely plugged into a proper 'GFCI' electrical outlet.
- 6- Test the 'GFCI' outlet by pressing its test switch. This should prove that the outlet is energized and will trip off to protect against a ground fault. Be sure to reset the 'GFCI' by pressing its reset switch.
- 7- Lift the float to prove that the pump will start when required. (Step 8 below will test submersible pumps with enclosed floats).

8- Put pails of water in the sump to prove that any check valve present will permit effluent to flow.

9- Observe that the plumbing can carry the effluent safely out of the residence.

SAFETY INSTRUCTIONS:

Before installation and operation, follow these procedures:

- A- Check with your local electrical and plumbing codes to ensure you comply with the regulations. These codes have been designed with your safety in mind. Be sure you comply with them.
- B- A separate circuit must be lead from the home electrical distribution panel properly protected with a fuse or a circuit breaker. We also required that a ground fault circuit be used as well as a 'GFCI' receptacle. Consult a licensed electrician for all wiring.
- C- The ground terminal on the three prong plugs should never be removed. They are supplied and designed for your protection.
- D- Never make adjustments to any electrical appliance or product with the power connected. Do not only unscrew the fuse or trip the breaker, remove the power plug from the receptacle.

IMPORTANT

ELECTRICAL CONNECTION:

For pumping systems using more than one pump, each pump needs to be connected to a separate dedicated circuit protected by a fuse or breaker. This way, the power supply of one pump will not stop operating if the fuse of one of the pumps burns or if the breaker of one of the pumps trips.

IMPORTANT NOTICE:

The following are minimum requirements in order to protect your residence from flooding. It is a small investment but it is your personal responsibility to protect your home, family and valuables. Failure to comply with the following requirements will also void your warranty:

- Two (2) pumps have to be installed in the sump pit. The first pump as a primary pump and the second pump as the backup unit.

- An Alarm system model T50454 has to be installed to advise you of any malfunctions.

- As sump pumps are electrically powered and activated so to prevent flooding, a battery powered back up pump model T00403 has to be installed to evacuate the water.

Pump selection, proper and adequate installation are a must to comply with local by-laws and need to be adhered to.

INSTALLATION STEPS:

STEP 1

Install your pump in a clean location where there is adequate room for servicing at a later date. Protection from freezing temperatures and good ventilation should be considered as well, to provide the pump an environment for long life. Do not use to pump gas or toxic fuels. This sump pump is designed to pump water only. The minimum discharge pipe size is 1 1/4". Friction losses in the discharge pipe must be taken into consideration when the horizontal offset is greater than 50 feet. The discharge pipe should be increased to 1 1/2" or 2". This will reduce friction losses and allow the pump to give maximum performance. More friction losses must also be taken into consideration when many elbows and fittings are installed in the discharge line. Each elbows and fittings must be considered as 1 feet of head. The float switch of your pump has been pre-set at the factory and does not need any adjustment. Never run the pump dry. Damage to the seal may occur. Fill pump pit or sump basin with water before turning on the power.

STEP 2

Assuming that you have a sump pit located in your basement floor... Your sump pit must be constructed from concrete, brick, tile or more recently a sump basin made from plastic and/ or fiberglass. The size of your sump pit must be 18" in diameter and no less than 25" deep. When pit is ready, proceed to next step.

STEP 3

At this step, you have the opportunity to install a 1 1/2" or a 1 1/4" discharge. We recommend a 1 1/2" ABS/DWV discharge. Install a check valve (T50362 in-line 1 1/2" or T50363 1 1/2" MNPT inlet and 1 1/2" or 2" outlet or T50353 1 1/4" MNPT inlet and

1 1/4" or 1 1/2" outlet) over the discharge of your pump and secure it with stainless steel clamps or glued nipple for ABS/DWV pipe. This check valve will allow easy access to pump, should service be required. Connect your pipe to the check valve. For twin systems, connect your pipe to the provided piping of the pumps. The check valves are already installed at the pump discharges.

STEP 4

Install and position your sump pump(s) in the centre of your sump pit or basin and ensure that there is clearance to allow the switch(es) a free working area without obstructions (pipe, pit's wall, power cord).

STEP 5

Install your discharge pipe from the system piping to the point of discharge or drain. For installation over 50 feet of horizontal friction discharge pipe, use a 2" pipe to reduce friction loss.

STEP 6

The switch(es) provided with your pump(s) are supplied with a serial electrical male plug. Fix the power cord of the pump into the piggy-back receptacle of the switch(es) and plug this one into electrical grounded outlet. We recommend that a licensed electrician be employed to do wiring. Permanently ground the motor in accordance to the electrical codes for your area. Do not use an extension cord to connect your pump to the power source. From your distribution panel to the receptacle, we recommend a wire gauge not smaller than 14 gauge. Use tape or tie wrap to fix power cords to discharge pipe.

STEP 7

Fill the sump pit or basin with water to test the operation of your sump pump. Allow the pump to go through several "on-off" cycle to assure satisfactory operation. If needed, see trouble shooting guide in this manual.

STEP 8

Review your installation with typical diagram. Check all connections for leaks.

MAINTENANCE:

Unplug the switch and pump motor power cord. Remove the pump from pit or basin. Remove trash accumulation and dirt from the pump and float switch. Be sure the float switch operates freely after cleaning. If tar or paint has been received in the pit or basin, use kerosene to remove residue from float switch or pump. Do not use strong paint solvents. Remove the screws that hold the strainer or the base to the bottom of the pump

body. Pry the base off the pump body carefully. Clean the impeller and volute passage way from any debris which may have become in contact with these parts. Again, If tar or paint has entered pump, clean with kerosene. Do not use strong paint solvents. Be sure impeller turns freely after cleaning. Check and clean away any debris which may be clogging the suction inlet, pump discharge, check valve and discharge line. Replace screws and return sump pump to sump pit or basin and reconnect to piping.

SUMP PUMP APPLICATION:

STEP 3

Prepare your choice of discharge pipe size and check valve.

STEP 2

Sump pit
18" diameter X 25" depth.

STEP 7

Fill the basin and test the operation.

STEP 8

Review and check connections for leaks.

STEP 6

Connect float and motor power cable. One receptacle per pump, on a dedicated circuit.

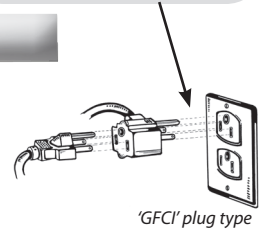

STEP 5

Install discharge pipe.

STEP 4

Install your pump in center of pit.

* Picture shown is an example only, it may vary from your pump model.

NOTICE:

This unit have been designed to pump water only. This unit is not designed for applications involving salt water, brine or any other liquids including petroleum products. Use with salt, brine or any other liquids including petroleum products will void the warranty.

TROUBLE SHOOTING GUIDE CHECK LIST

PROBABLE CAUSE

ACTION

Motor does not run

Switch is off position
Blown fuse
Tripped breaker
Plug disconnected
Corroded plug
Low water level
Thermal overcharge
Defective switch/float
Defective motor
Improper float position

Turn switch to on position
Replace
Reset
Re-install
Clean prongs
Add water and verify
Cool the motor
Replace
Replace/repair
Check movement

Pump does not deliver to full capacity

Jammed impeller
Plugged check valve
Blocked suction/inlet
Discharge leak
Blocked line/pipe
Worn impeller
Defective motor

Clean
Clean/replace
Check for debris in pit and clean
Repair
Check for debris or ice
Repair/replace
Replace

Pump does not shut off

Defective switch
Float obstruction
Blocked suction/inlet

Replace
Adjust/check
Check for debris in pit and clean

TO THE END CONSUMER:

If you have any problem with the product, before advising the store, where you've purchased the pump, please contact us at 514 337-4415, and ask for our customer service desk. They will be pleased to help you with any questions you might have, concerning your installation.

NOTES: